

184600/3

INSTRUCTION MANUAL

EMERGENCY POWER EQUIPMENT
UNIVERSAL MINI INVERTER
PURE SINUSOIDAL AC OUTPUT
OUTPUT VOLTAGE AUTO SETTING EQUAL TO INPUT VOLTAGE
AUTO DIMMING (0-10V) OF CONNECTED LOAD



IMPORTANT SAFEGUARDS

WHEN USING ELECTRICAL EQUIPMENT, BASIC SAFETY PRECAUTIONS SHOULD ALWAYS BE FOLLOWED, INCLUDING THE FOLLOWING

READ AND FOLLOW ALL SAFETY INSTRUCTIONS

1. To prevent electric shock, switch off the mains power supply until installation is complete and AC input power is supplied to this product.
2. This product requires an unswitched AC power supply of 120-277V, 50/60Hz.
3. Make sure all connections are in accordance with the National or Canadian Electrical code and any local regulations.
4. To reduce the risk of electrical shock, disconnect both normal power, emergency power supplies and unit connector of this product before servicing.
5. For emergency operation of LED, incandescent, fluorescent fixtures and screw-base lamps.
6. The product is UL Listed for field installation, and use with grounded, Listed, damp location rated fixtures.
7. Use this product in 0°C minimum, 50°C maximum ambient temperatures (Ta). It can provide minimum 90 minutes illumination under the emergency mode.
8. This product is suitable for use in dry or damp locations. Do not use outdoors. Do not mount it near gas, heaters, air outlets or other hazardous locations.
9. Do not attempt to service the batteries. A sealed, non-maintenance battery is used that is not field replaceable. Contact the manufacturer for information or service.
10. The use of accessory equipment not recommended by the manufacturer may cause an unsafe condition and void warranty.
11. Do not use this product for other than intended use.
12. Installation and service should be performed by qualified service personnel.
13. This product should be mounted in locations and at heights where it will not readily be subjected to tampering by unauthorized personnel.



**THIS PRODUCT CONTAINS A RECHARGEABLE LI-ION BATTERY.
THE BATTERY MUST BE RECYCLED OR DISPOSED OF PROPERLY.**

INSTALLATION



CAUTION: MAKE CERTAIN THE AC POWER IS OFF AND THE 184600/3 UNIT CONNECTOR IS DISCONNECTED UNTIL THE INSTALLATION IS COMPLETE.

1. SPECIFICATION OF 184600/3

Model	Voltage		Output Power
	Input	Output	
184600 184603	120V/60Hz	120V/60Hz	184600 Max. 36W 184603 Max. 27W With dimmable or non-dimmable load
	230V/50Hz	230V/50Hz	
	277V/60Hz	277V/60Hz	

2. INSTALLING THE 184600/3

The 184600/3 can be mounted inside or outside (nearby or on top of) the luminaire.

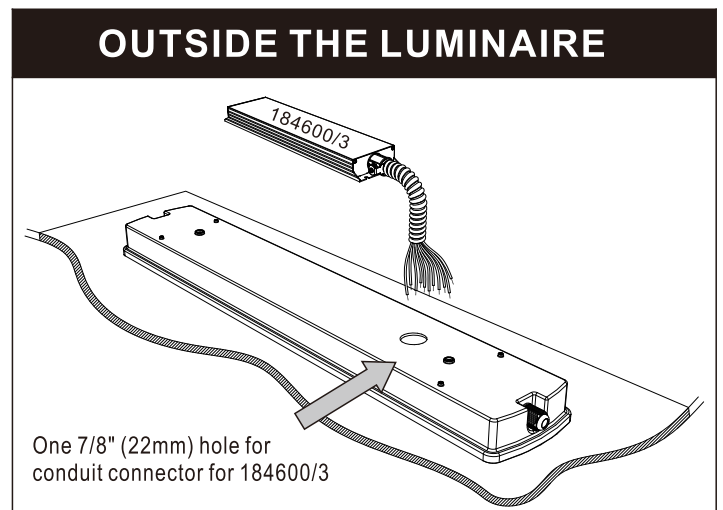
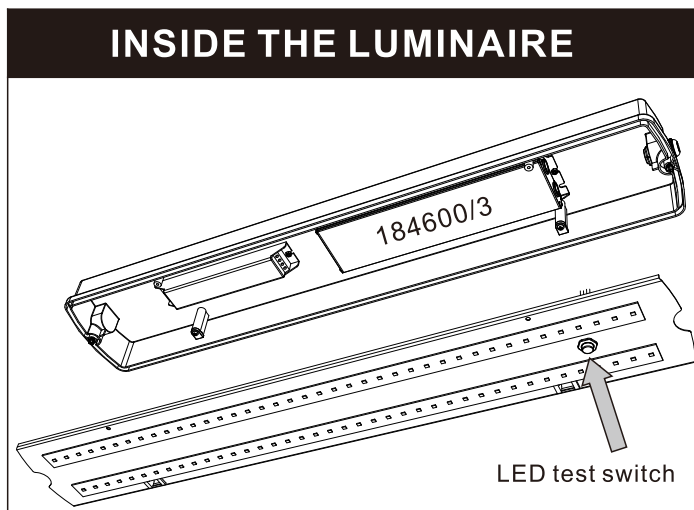

3. INSTALLING THE LED TEST SWITCH (LTS)

Select a convenient location for the LTS so that it can be seen after installation. Drill a 1/2" (12 mm) hole for mounting the LTS. Connect the wires from LTS to the 184600/3 model according to the wiring diagram on page 3.

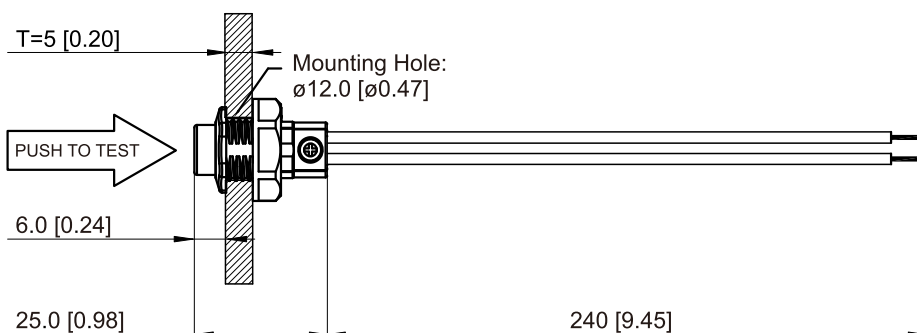

All dimensions are typical

Dimension unit: mm [inch]
Tolerance: ±1 [0.04]

WIRING



CAUTION: DO NOT MATE UNIT CONNECTOR UNTIL INSTALLATION IS COMPLETE AND AC POWER IS SUPPLIED.

1. The 184600/3 requires an unswitched AC power supply of 120-277 volt, 50/60Hz.
2. Refer to the wiring diagrams below. Make connections in the following order ①②③④⑤⑥⑦
3. Consult the factory for other wiring diagrams.

WIRING DIAGRAM FOR 0-10V DIMMABLE EMERGENCY LIGHTING SYSTEM

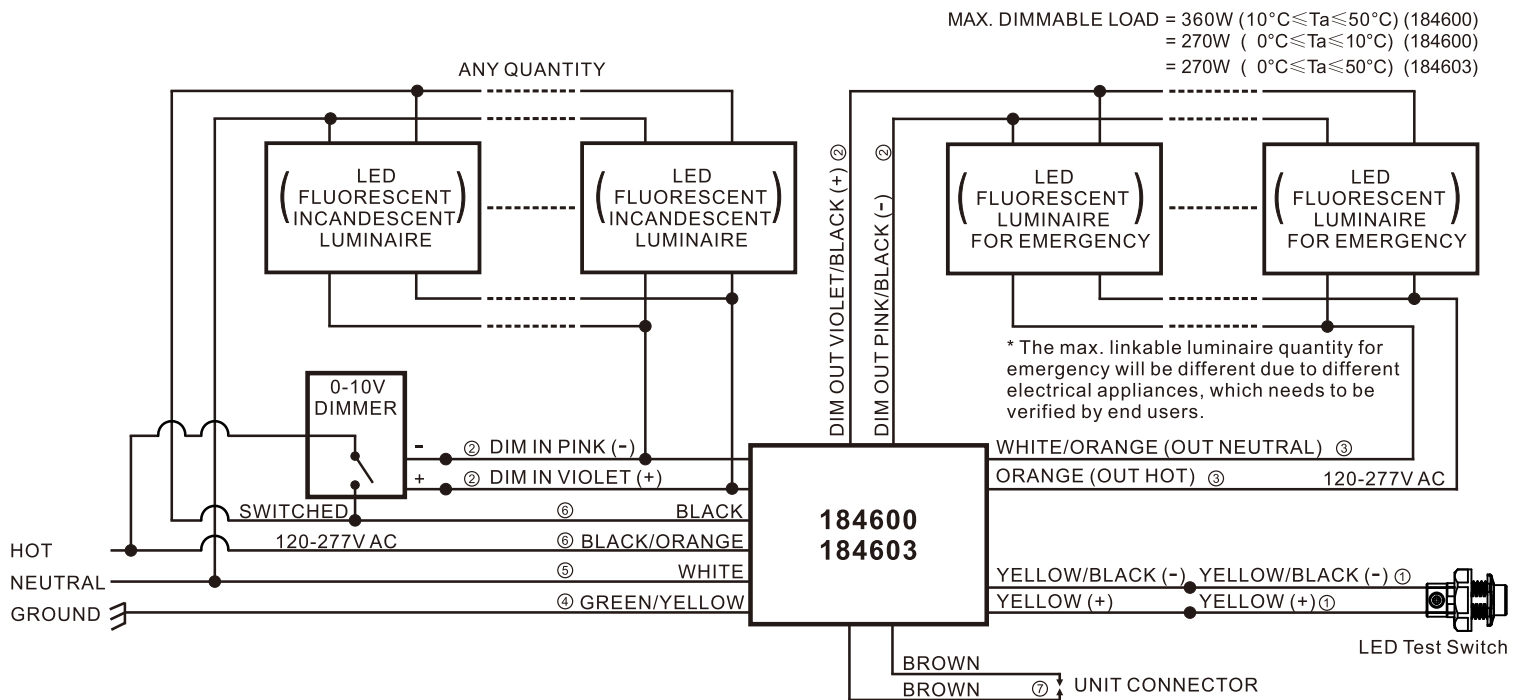

WIRING DIAGRAM FOR NON-DIMMABLE EMERGENCY LIGHTING SYSTEM

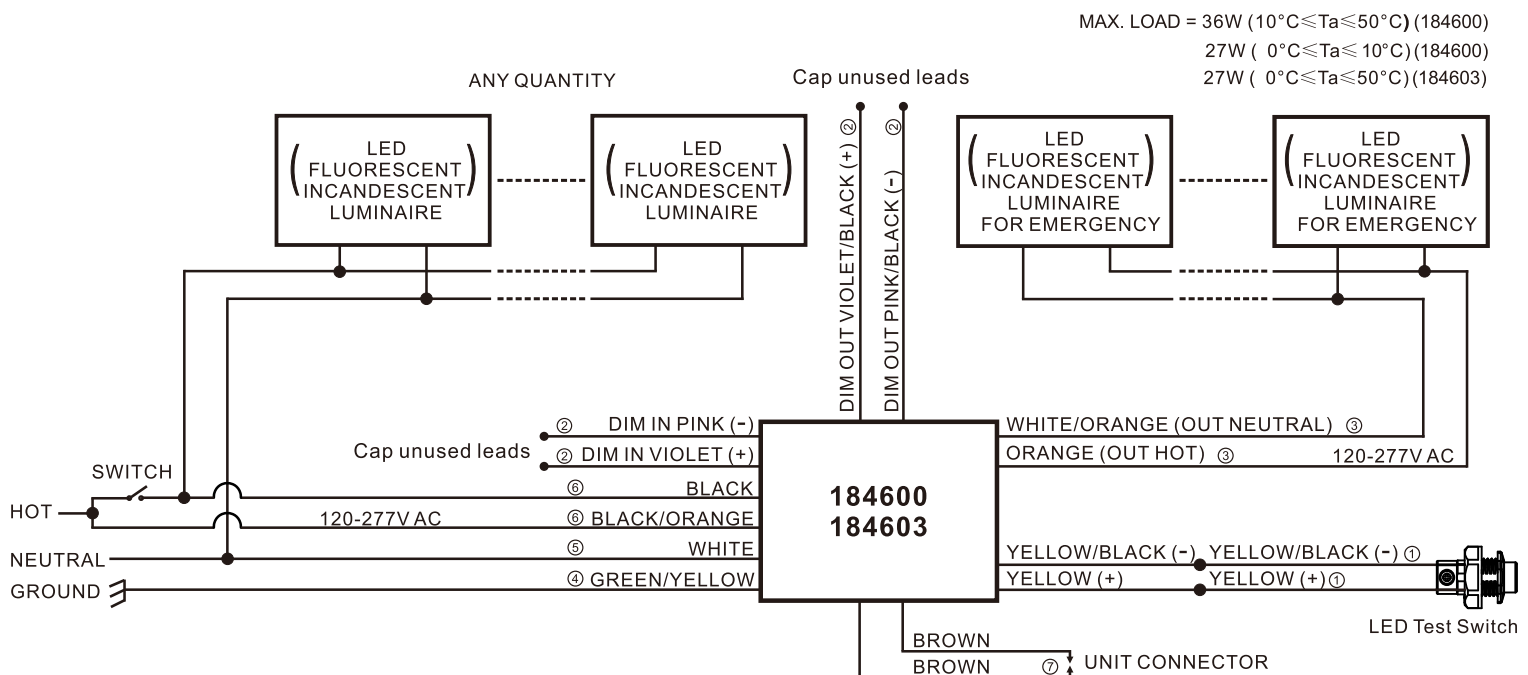

OPERATION / TESTING / MAINTENANCE

OPERATION

When AC power is applied, the LED test switch is illuminated, indicating that the batteries are being charged. When AC power fails, the 184600/3 automatically switches to emergency power, operating the lighting load at rated emergency power. During power failure, the LED test switch will be off. When the AC power is restored, the emergency 184600/3 switches the system back to normal mode of operation and resumes battery charging. The minimum emergency operation time is 90 minutes. A short term discharge test may be conducted after unit has been charging for 1 hour. Charge for 24 hours before conducting a long term discharge test.

TESTING AND MAINTENANCE

The following Periodic testing is recommended to ensure the system is working correctly.

1. Visually inspect the LED test switch (LTS) monthly. It should be illuminated when AC power is applied.
2. Conduct a 60-second discharge test by switching off the emergency breaker every month. The LTS will be off.
3. Conduct a 90-minute discharge test once per year. The LTS will be off during test.

AUTO TEST

The 184600/3 has an Auto Test feature which saves cost by reducing the need for manual testing.

1. Initial Auto Test

When the system is connected properly and powered on, the 184600/3 will perform an initial Auto Test. If any abnormal conditions exist, the LTS will blink quickly. Once the abnormal condition is corrected, the LTS will function correctly.

2. Preprogrammed Scheduled Auto Test

a) The unit will conduct the first Monthly Auto Test after 24 hours and up to 7 days after initial power on. Then monthly tests will be performed every 30 days.

b) Annual Auto test will occur every 52 weeks after initial power on.

- Monthly Auto Test

The Monthly Auto Test shall be executed every 30 days, and will test;

Normal to emergency transfer function, emergency, charging and discharging conditions are normal.

Monthly test time is approximately 30 seconds.

- Annual Auto Test

Annual Auto Test will occur every 52 weeks after the initial 24 hours full charge, and will test;

Proper initial battery voltage, 90-minute emergency operation and acceptable battery voltage at the end of the full 90-minute test.

If the Auto Test is interrupted by a power failure, a full 90-minute Auto Test will occur again 24 hours after the power is restored. If the power failure causes the battery to fully discharge, the product will restart the Initial Auto Test and Preprogrammed Scheduled Auto Test.

MANUAL TEST

1. Press the LTS 2 times continuously within 3 seconds to force a 60-second monthly test. After the test is complete, the next (30-day) monthly test will count from this date.

2. Press the LTS 3 times continuously within 3 seconds to force a 90-minute annual test. After the test is completed, the next (52-week) annual test will count from this date.

3. During any manual test, press and hold the LTS for greater than 3 seconds to terminate a manual test. The Preprogrammed Scheduled Auto Test time will not change.

LED TEST SWITCH CONDITIONS

LTS Slow Blinking: Normal Charging

LTS On: Battery Fully Charged - Normal Condition

LTS Off: Power Failure

LTS Gradual Change: In Testing Mode

LTS Quickly Blinking: Abnormal Condition - Corrective Action Required

PRESET DIMMING TECHNOLOGY

The 184600/3 utilizes customized preset dimming technology which allows for multiple 0-10 Vdc controlled dimmable luminaires up to 360W (for 184600) and 270W (for 184603) to automatically adjust and shares the total 36W (for 184600) or 27W (for 184603) emergency power evenly between 2 or more luminaires. The luminaires must be controlled by a single (0-10Vdc) dimming control device. When non dimmable loads are used, the normal and emergency output will be limited to a max. of 36W (for 184600) or 27W (for 184603).